

MAC 401 Dual™

user manual



Martin®

Dimensions

All dimensions are in millimeters

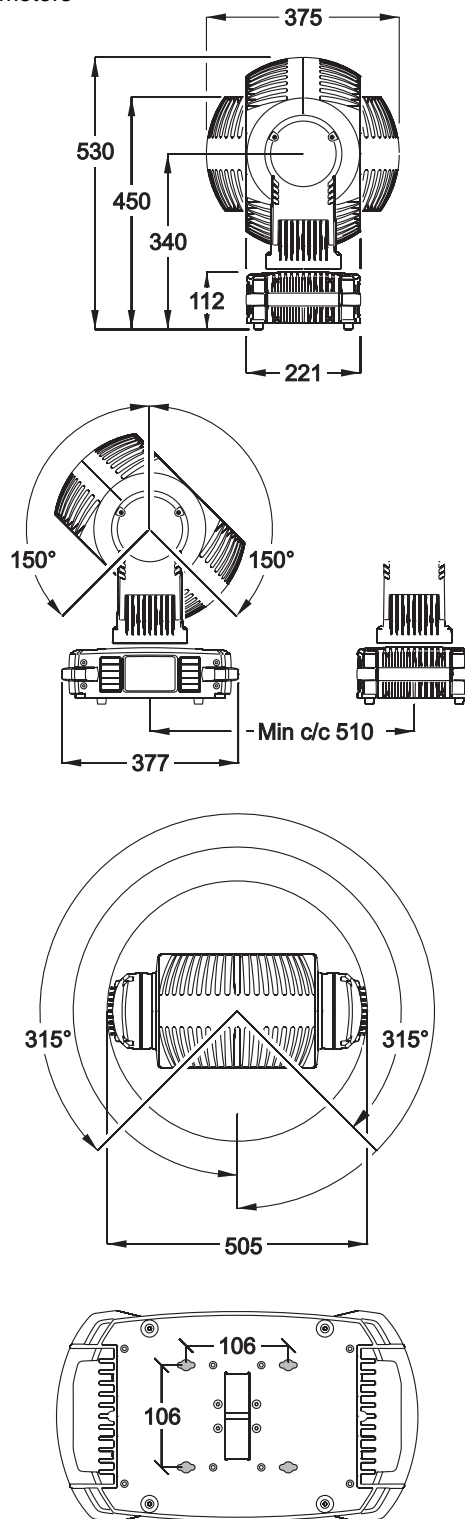

©2009-2010 Martin Professional A/S. Information subject to change without notice. Martin Professional A/S and all affiliated companies disclaim liability for any injury, damage, direct or indirect loss, consequential or economic loss or any other loss occasioned by the use of, inability to use or reliance on the information contained in this manual. The Martin logo, the Martin name and all other trademarks in this document pertaining to services or products by Martin Professional A/S or its affiliates and subsidiaries are trademarks owned or licensed by Martin Professional A/S or its affiliates or subsidiaries. The use of certain patents in Martin™ MAC 401™ products is licensed by Color Kinetics, Inc. (see details printed on product).

Safety Information



WARNING!

Read the safety precautions in this section before installing, powering, operating or servicing this product.

The following symbols are used to identify important safety information on the product and in this manual:



DANGER!
Safety hazard.
Risk of severe injury or death.



DANGER!
Hazardous voltage. Risk of lethal or severe electric shock.



WARNING!
Fire hazard.



WARNING!
LED light emission. Risk of eye injury.



WARNING!
Burn hazard. Hot surface. Do not touch.



WARNING!
Wear protective eyewear.



WARNING! Refer to user manual.



Warning! Class 3B LED product. Do not look into the beam at a distance of less than 1 meter (3 feet 4 inches) from the front surface of the product. Do not view the light output with optical instruments or any device that may concentrate the beam.



This product is for professional use only. It is not for household use.

This product presents risks of severe injury or death due to fire and burn hazards, electric shock and falls.



Read this manual before installing, powering or servicing the fixture, follow the safety precautions listed below and observe all warnings in this manual and printed on the fixture. If you have questions about how to operate the fixture safely, please contact your Martin supplier or call the Martin 24-hour service hotline on +45 8740 0000, or in the USA on 1-888-tech-180.



PROTECTION FROM ELECTRIC SHOCK

- Disconnect the fixture from AC power before removing or installing any cover or part – including fuses – and when not in use.
- Always ground (earth) the fixture electrically.
- Use only a source of AC power that complies with local building and electrical codes and has both overload and ground-fault (earth-fault) protection.
- Before using the fixture, check that all power distribution equipment and cables are in perfect condition and rated for the current requirements of all connected devices.
- Isolate the fixture from power immediately if any power connector, power cable, seal, cover or other component is damaged, defective, deformed, wet or showing signs of overheating. Do not reapply power until repairs have been completed.
- Do not expose the fixture to rain or moisture.
- Refer any service operation not described in this manual to a qualified technician.



PROTECTION FROM BURNS AND FIRE

- Do not operate the fixture if the ambient temperature (T_a) exceeds 40° C (104° F).
- The exterior of the fixture becomes hot during use. Avoid contact by persons and materials. Allow the fixture to cool for at least 10 minutes before handling.
- Keep all combustible materials (e.g. fabric, wood, paper) at least 200 mm (8 in.) away from the head.
- Keep flammable materials well away from the fixture.
- Ensure that there is free and unobstructed airflow around the fixture.
- Do not illuminate surfaces within 200 mm (8 in.) of the fixture.
- Do not attempt to bypass thermostatic switches or fuses. Replace defective fuses with ones of the specified type and rating.
- Do not modify the fixture in any way not described in this manual
- Install only genuine Martin parts.



PROTECTION FROM INJURY

- Do not look at LEDs from a distance of less than 1 meter (3 feet 4 inches) from the front surface of the fixture without protective eyewear such as shade 4-5 welding goggles. At less than this distance, the LED emission can cause eye injury or irritation. At distances of 1 meter (3 feet 4 inches) and above, light output is harmless to the naked eye provided that the eye's natural aversion response is not overcome.
- Do not look at LEDs with magnifiers, telescopes, binoculars or similar optical instruments that may concentrate the light output.
- Ensure that persons are not looking at the LEDs from within 1 meter (3 feet 4 inches) when the product lights up suddenly. This can happen when power is applied, when the product receives a DMX signal or when service menu items are selected in the **SERV** menu.
- To minimize the risk of eye irritation or injury, set the zoom to wide angle and disconnect the fixture from power at all times when the fixture is not in use, and provide well-lit conditions to reduce the pupil diameter of anyone working on or near the fixture.
- Install as described in this manual a secondary attachment such as a safety cable that is approved by an official body such as TÜV as a safety attachment for the weight of all the fixtures it secures. The safety cable must comply with EN 60598-2-17 Section 17.6.6 and be capable of bearing a static suspended load ten times the weight of the fixture.
- If suspending from a rigging structure, attach the fixture with two evenly spaced clamps. Do not use only one clamp.
- Ensure that any supporting structure and/or hardware used can hold at least 10 times the weight of all the devices they support.
- Allow enough clearance around the head to ensure that it cannot collide with an object or another fixture when it moves.
- Check that all external covers and rigging hardware are securely fastened.
- Block access below the work area and work from a stable platform whenever installing, servicing or moving the fixture.
- Do not operate the fixture with missing or damaged covers, shields or any optical component.



Contents

Dimensions	2
Safety Information.....	3
Introduction	6
Unpacking	6
Using for the first time	6
Connections panel	8
AC power	9
Power voltage	9
Power cable and plugs	9
Data link	11
Tips for reliable DMX data transmission	11
Connecting the DMX data link	11
Physical installation	12
Placing the fixture on a flat surface	12
Mounting the fixture on a truss	12
Setup.....	13
Control panel and menu navigation	13
Restoring factory default settings	14
Control modes	14
Pixel grouping	14
DMX.....	15
Tailoring performance	15
Effects.....	17
Service and maintenance.....	19
Cleaning.....	19
Removing and installing head modules	20
Control menu service utilities.....	21
Fixture readouts.....	21
Lubrication.....	21
Fuse replacement	22
Diagnostic feedback	22
DMX protocol	23
LEE colors and their RGB equivalents	29
Onboard control menus.....	30
Single head module operation.....	30
Dual head module operation	32
Adjustment submenu.....	35
Troubleshooting	36
Specifications	37

Introduction

Thank you for selecting the MAC 401 Dual™, an intelligent lighting fixture from Martin Professional™. This LED-based moving-head washlight features:

- 36 multi-color high-power emitters
- DMX control
- Twin-face head that can operate with one or two modular plug-and-play LED arrays
- Onboard control panel with LED display
- RGB (red, green, blue), HSV (hue, saturation, value) and CTC (color temperature control) control options
- Electronic 'color wheel' feature
- Two ranges of pre-programmed superimposable dynamic effects
- Four pixel grouping options
- Smooth electronic dimming
- Electronic strobe with pulse effects
- Motorized zoom providing beam angles from 20° - 50°, as well as 16° Hypermode effect
- 630° pan and 300° tilt ranges

For the latest firmware updates, documentation, and other information about this and all Martin Professional products, please visit the Martin website at <http://www.martin.com>

Comments or suggestions regarding this document may be e-mailed to service@martin.dk or posted to:

Service Department
Martin Professional A/S
Olof Palmes Allé 18
DK-8200 Aarhus N
Denmark



Warning! Read "Safety Information" on page 3 before installing, powering, operating or servicing the MAC 401 Dual™.

Unpacking

The following items are included with the MAC 401 Dual™:

- One head module (installed)
- Two clamp attachment brackets with quarter-turn fasteners
- This user manual
- A Neutrik PowerCon input connector
- 2 x 10 AT mains fuses (installed)

Using for the first time

Before applying power to the fixture:

- Check the Martin Professional website at www.martin.com for the most recent user documentation and technical information about the MAC 401 Dual™. Martin user manual revisions are identified by the letter at the bottom of page 2.
- Carefully review "Safety Information" on page 3.
- Check that the fixture's power voltage and frequency ranges match the local AC mains power source. See "Power voltage" on page 9.

- Prepare the cabling and connectors for running the fixture off AC power as described in “Power cable and plugs” on page 9.

Connections panel

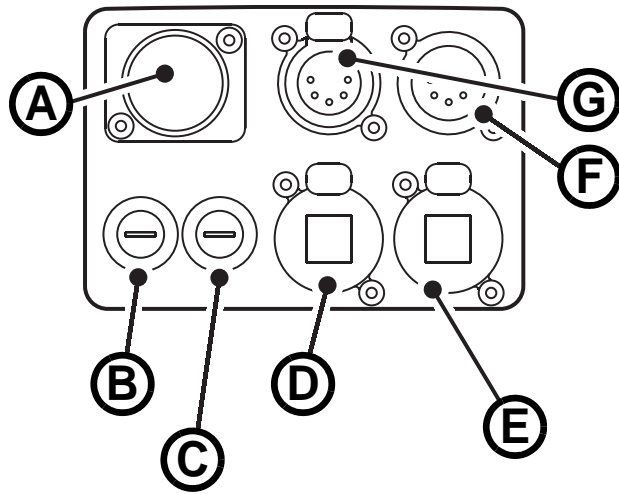

- A – AC mains power input (Neutrik PowerCon)
- B – Fuseholder, mains fuse 1
- C – Fuseholder, mains fuse 2
- D – Ethernet 1 (RJ-45, for future use)
- E – Ethernet 2 (RJ-45, for future use)
- F – DMX out (5-pin XLR)
- G – DMX in (5-pin XLR)

Figure 1: Connections panel overview

AC power



Warning! Read “Safety Information” starting on page 3 before connecting the MAC 401 Dual™ to AC mains power.

For protection from electric shock, the MAC 401 Dual™ must be grounded (earthed). The AC power distribution circuit must be equipped with a fuse or circuit breaker and ground-fault (earth-fault) protection.



The MAC 401 Dual™ does not have a power on/off switch. To shut down power urgently, disconnect the fixture’s power input connector.

Important! Do not use an external dimming system to supply power to the MAC 401 Dual™, as this may cause damage to the fixture that is not covered by the product warranty.

The MAC 401 Dual™ can be hard-wired to a building electrical installation if you want to install it permanently. If you do this, provide a means of shutting down power near the fixture. Alternatively a power cable (not supplied) with a power plug suitable for local power output sockets can be used to supply the fixture with AC mains power.

Power voltage



Warning! Check that the voltage range specified on the fixture’s serial number label matches the local AC mains power voltage before applying power to the fixture.

MAC 401 Dual™ fixtures are factory-configured to accept AC mains power at 100-240 V nominal, 50/60 Hz. Do not apply AC mains power to the fixture at any other voltage than that specified on the fixture’s serial number label.

Power cable and plugs

The fixture must be connected to AC power using three-conductor cable that is rated 20 A minimum (12 AWG or 2.5 mm²), with a diameter of 5 - 15 mm (0.2 - 0.6 in.). The cable jacket must be SJT type or better and heat-resistant to 90° C (194° F) minimum. A power cable is not supplied with the product.

The MAC 401 Dual™ is supplied with a male Neutrik PowerCon NAC3FCA locking 3-pole input connector that can be attached to the end of the power cable.

The power cable can either be permanently connected to a building’s electrical installation circuits (in this case an external power switch must be installed close to the fixture) or fitted with a power plug that is suitable for the local AC mains power outlets.

If you decide to install a power plug on the fixture’s power cable, install a grounding-type (earthed) plug that is correctly rated for the current and power requirements of the fixture. Follow the plug manufacturer’s instructions. Table 1 shows standard wire color-coding schemes and some possible pin identification schemes; if pins are not clearly identified, or if you have any doubts about proper installation, consult a qualified electrician.



Wire Color (EU)	Wire Color (US)	Conductor	Symbol	Screw (US)
brown	black	live	L	yellow or brass
blue	white	neutral	N	silver
yellow/green	green	ground (earth)	 or 	green

Table 1: Wire color-coding and power connections

Attaching a cable to the male input connector

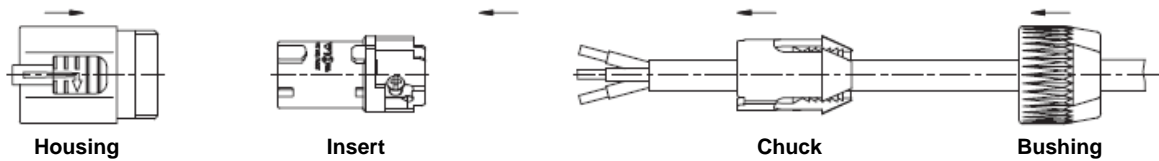

To attach a power cable to the supplied input connector:

1. Slide the bushing over the cable.
2. Slide the white chuck over cables with a diameter (D_a) of 5 - 10 mm (0.2 - 0.4 in.), or the black chuck over cables with a diameter of 10 - 15 mm (0.4 - 0.6 in.).
3. Prepare the end of the cable by stripping 20 mm (0.8 in.) of the cable's outer jacket.
4. Strip 8 mm (1/3 in.) from the end of each of the wires.
5. Insert each of the wire ends into the appropriate terminal (see Table 1 above) and fasten the clamping device using a small flathead screw driver.
6. Push and insert the chuck into the housing (note that there is a raised key on the chuck to ensure that it is oriented correctly).
7. Fasten the bushing, using a wrench, to a torque of 2.5 Nm (1.8 lb-ft).

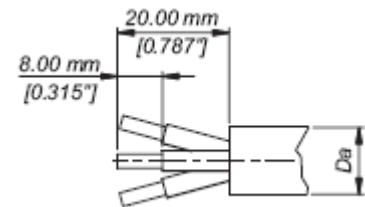

Cable end

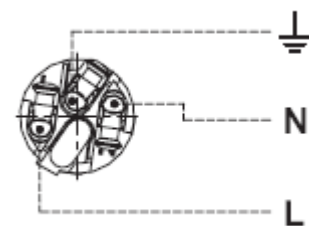

Terminals

Illustrations on this page used by kind permission of Neutrik AG.

Data link

A data link is required in order to control a MAC 401 Dual™ via DMX.

The MAC 401 Dual™ has 5-pin locking XLR connectors for DMX data input and output. The pin-out on XLR connectors is pin 1 = shield, pin 2 = cold (-), and pin 3 = hot (+).

Pins 4 and 5 in the 5-pin XLR connectors are not used in the MAC 401 Dual™ but they are connected in to the output connector to allow any data that may be present on pins 4 and 5 to pass through the fixture.

Sockets are wired in parallel: both inputs connect to both outputs.

Two RJ-45 connectors are also provided, making the MAC 401 Dual™ ready for future data communication options over an Ethernet link. If you wish to use these options when available, ensure that the latest available firmware is installed in the fixture.

Tips for reliable DMX data transmission

- Use shielded twisted-pair cable designed for RS-485 devices: standard microphone cable cannot transmit control data reliably over long runs. 24 AWG cable is suitable for runs up to 300 meters (1000 ft). Heavier gauge cable and/or an amplifier is recommended for longer runs.
- To split the link into branches, use a splitter such as the Martin™ RS-485 Opto-Splitter™ 4-channel optically isolated splitter/amplifier.
- Do not overload the link. Up to 32 devices may be connected on a serial link.
- Terminate the link by installing a termination plug in the output socket of the last fixture. The termination plug, which is a male XLR plug with a 120 Ohm, 0.25 Watt resistor soldered between pins 2 and 3, “soaks up” the control signal so it does not reflect and cause interference. If a splitter is used, terminate each branch of the link.

Connecting the DMX data link

1. Connect the DMX data output from the controller to the MAC 401 Dual™'s 5-pin male XLR input socket.
2. Continue connecting fixtures, DMX output to DMX input, in one single chain.
3. Use a splitter-amplifier such as the Martin RS-485 Optosplitter (P/N 90758060) if you need to branch the link into two chains.
4. Insert a DMX termination plug in the DMX output of the last fixture on each chain.

Physical installation

The MAC 401 Dual™ can be placed on a horizontal surface such as a stage or clamped to a truss in any orientation using the quarter-turn clamp brackets supplied with the fixture and a half-coupler (not supplied).



Warning! Attach an approved safety cable to the attachment point on the connections panel (see Figure 2).

Check that all surfaces to be illuminated are minimum 200 mm (8 in.) from the fixture, that combustible materials (wood, fabric, paper, etc.) are minimum 200 mm (8 in.) from the head, that there is free airflow around the fixture and that there are no flammable materials nearby.

Make sure that it is impossible for the moving head to collide with another fixture or other object.

Ensure that wherever the product is installed that people are not able to look directly down the LED beam zone from within a distance of 1 meter (3 feet 4 inches). At less than this distance, the LED emission can cause eye injury or irritation. At distances of 1 meter (3 feet 4 inches) and above, light output is harmless to the naked eye provided that the eye's natural aversion response is not overcome.

Placing the fixture on a flat surface

The MAC 401 Dual™ can be placed on a stage or other level, flat surface. Check that the surface can support at least 10 times the weight of all fixtures and equipment to be installed on it.



Warning! The supporting surface must be hard and flat or air vents in the base may be blocked, which will cause overheating. Secure the fixture against falling. Attach a securely anchored safety cable to the safety cable attachment point (see Figure 2) if the fixture is to be placed above ground level in any location where it may fall and cause injury or damage.

Mounting the fixture on a truss

The MAC 401 Dual™ can be clamped to a truss or similar rigging structure in any orientation. Clamp brackets can be attached to the base of the fixture using quarter-turn quick connectors.



Warning! Use two clamps to rig the fixture. Lock each clamp bracket by turning both 1/4-turn fasteners fully clockwise.

To clamp a MAC 401 Dual™ to a truss:

1. Check that the rigging structure can support at least 10 times the weight of all fixtures and equipment to be installed on it.
2. Obtain two rigging clamps and check that they are undamaged and can bear at least 10 times the weight of the fixture. Bolt the clamps securely to the supplied clamp brackets with a minimum grade 8.8 M12 bolt and lock nut.
3. See Figure 2. Align each of the two clamp brackets with two mounting points in the base. Insert the quarter-turn fasteners into the base and turn all levers a full 90° clockwise to lock.
4. Block access under the work area. Working from a stable platform, hang the fixture on the truss. Tighten the rigging clamps.
5. Secure the fixture against clamp or bracket failure with a secondary attachment such as a safety cable that can bear at least 10 times the weight of the fixture using the attachment point in the base of the fixture (arrowed in Figure 2). This attachment point is designed to accept a carabiner clamp. Do not use any other part of the fixture as a safety cable attachment point.
6. Check that the head will not collide with other fixtures or objects.

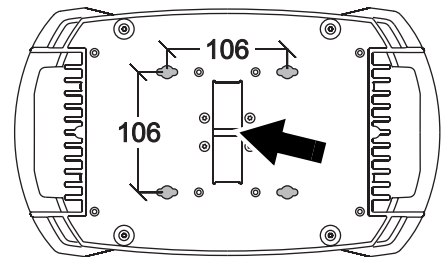

Figure 2: Safety cable attachment point

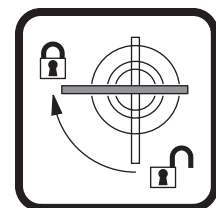

Figure 3: Quarter-turn fasteners

Setup



Warning! Read “Safety Information” on page 3 before installing, powering, operating or servicing the MAC 401 Dual™.

Control panel and menu navigation

The onboard control panel and LED display are used to set the MAC 401 Dual™’s DMX address, configure individual fixture settings (personality), read out data and execute service utilities. See “Onboard control menus” on page 30 for a complete list of menus and commands.

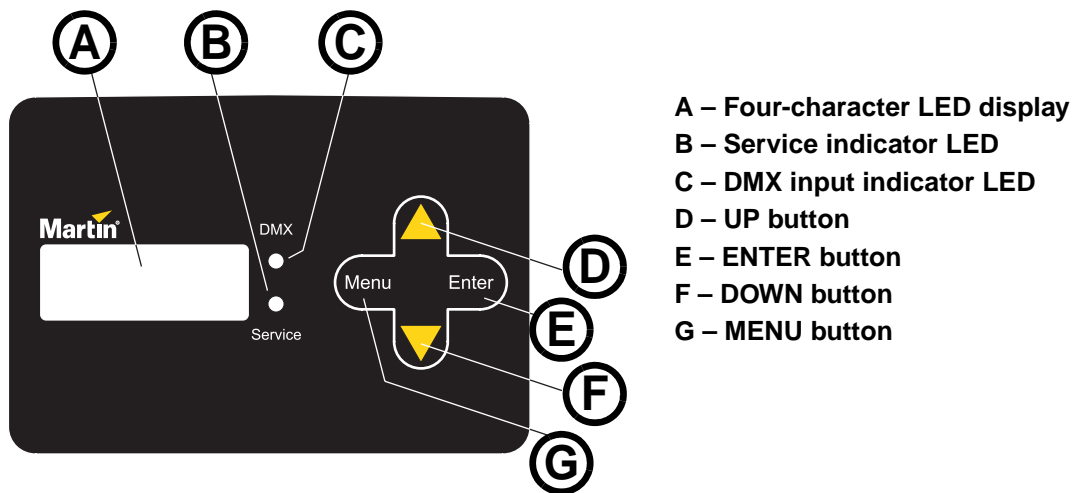

Figure 4: Control panel and display

Using the control buttons

See Figure 4.

- Press [Menu] to enter a menu, to escape a function or move back one level in the menu structure.
- Press the [Up] and [Down] buttons to scroll within a menu or increase and decrease values.
- Press [Enter] to enter a submenu or activate a function. Note: [Enter] must be pressed and held for a few seconds to enter the Service menu (**SERV**).

Control menu shortcuts

- Hold [Menu] and press [Up] - Resets fixture
- Hold [Menu] and [Enter] during fixture reset - Freezes pan and tilt
- Hold [Up] and press [Down] - Inverts display for easy reading when the fixture is suspended base up.

Display functions

The DMX address is shown in the display panel when the MAC 401 Dual™ is powered on and has reset.

By default the display is set to go into to sleep mode 2 minutes after the last key press. To reactivate the display, press any key. To modify or disable this setting see “Display settings” on page 16.

LED indicators

The two LEDs on the right of the display indicate fixture status:

- The DMX LED lights when the fixture is receiving a valid DMX signal.
- The SERVICE LED lights if the fixture requires a service intervention. At the same time, a message appears in the display indicating the type of service required.

The SERVICE LED blinks when the fixture is in factory service mode.

Restoring factory default settings

The MAC 401 Dual™ factory default settings can be restored by scrolling to the main **FACT** menu, pressing [Enter], opening the **FACT** submenu and applying a **LOAD** command.

Three sets of custom user settings can also be stored and recalled from the main **FACT** menu.

Control modes

The MAC 401 Dual™ can be set to various combinations of DMX control modes that are selected in the **DMX - PSET** menu. See “DMX protocol” on page 23 for details of the DMX commands available in the different modes.

DMX control modes

The MAC 401 Dual™ can be set to four DMX control modes in the **DMX - PSET** submenu:

- **RGBX** – RGB color mixing with dynamic effects available (this is the default control mode setting)
- **HSX** – Hue, saturation, value color control with dynamic effects available
- **RGB** – RGB color mixing with no dynamic effects
- **HS** – Hue, saturation, value color control with no dynamic effects

Color temperature control is available in all four modes.

Pixel grouping

In all four DMX control modes, the LEDs in the MAC 401 Dual™ can be controlled collectively as one single group or split into two or four segments that can be controlled collectively as though they were individual pixels.

The following options are available in the **DMX - PGRP** submenu:

- **1** – LEDs are divided into four segments **A** to **D**, giving Individual control of four pixel groups
- **2V** – LEDs are divided vertically into two segments **A** and **B**, giving individual control of two pixel groups
- **2H** – LEDs are divided horizontally into two segments **A** and **B**, giving individual control of two pixel groups
- **All** – All LEDs are controlled together as one pixel (this is the default pixel grouping setting).

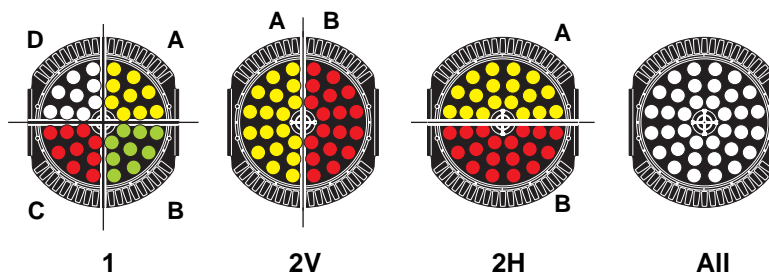

Figure 5: Pixel grouping (fixture on base, tilt positive)

The **DMX - PINV** submenu can be used to invert the pixel settings, from left to right and top to bottom.

DMX

The different pixel grouping, control mode and number of head modules fitted determine the number of DMX channels used:

- Each pixel group requires four DMX channels (for Red/Green/Blue/CTC or Hue/Saturation/Value/CTC). See “Pixel grouping” above.
- Control modes that incorporate effects use eight additional DMX channels. See “Control modes” above.
- When two head modules are installed, the DMX protocol is repeated in full for the second module, but pan/tilt and fixture control channels are disabled.

The following table gives an overview of the number of channels used and the control menu settings applied in the various modes.

PSET	PGRP	Mode	Number of channels
RGB	1	RGB, no dynamic effects, individual control of 4 quadrant-split LED groups	25
RGB	2H	RGB, no dynamic effects, individual control of 2 horizontally split LED groups	17
RGB	2V	RGB, no dynamic effects, individual control of 2 vertically split LED groups	17
RGB	All	RGB, no dynamic effects, collective control of all LEDs	13
HS	1	HSV, no dynamic effects, individual control of the 4 quadrant-split LED groups	25
HS	2H	HSV, no dynamic effects, individual control of 2 horizontally split LED groups	17
HS	2V	HSV, no dynamic effects, individual control of 2 vertically split LED groups	17
HS	All	HSV, no dynamic effects, collective control of all LEDs	13
RGBX	1	RGB, dynamic effects, individual control of the 4 quadrant-split LED groups	33
RGBX	2H	RGB, dynamic effects, individual control of 2 horizontally split LED groups	25
RGBX	2V	RGB, dynamic effects, individual control of 2 vertically split LED groups	25
RGBX	All	RGB, dynamic effects, collective control of all LEDs (default setting)	21
HSX	1	HSV, dynamic effects, individual control of the 4 quadrant-split LED groups	33
HSX	2H	HSV, dynamic effects, individual control of 2 horizontally split LED groups	25
HSX	2V	HSV, dynamic effects, individual control of 2 vertically split LED groups	25
HSX	All	HSV, dynamic effects, collective control of all LEDs	21

Table 2: DMX channel use in different mode settings

DMX address setting

The DMX address, also known as the start channel, is the first channel used to receive instructions from the controller. For independent control, each fixture must be assigned its own control channels. Two MAC 401 Dual™ fixtures may share the same address, however, if identical behavior is desired. Address sharing can be useful for diagnostic purposes and symmetrical control, particularly when combined with the inverse pan and tilt options.

The DMX address is configured using the **ADDR** menu in the control panel. The highest address available is reduced depending on mode settings so that the fixture will always have enough DMX channels in the 512 available in a DMX universe. If the fixture is set up so that it uses 33 DMX channels, for example, the highest address available will be 480.

Tailoring performance

The following performance options are available in the **PERS** menu.

Pan and tilt movement

The MAC 401 Dual™ provides several options for optimizing movement for different applications.

- Pan and tilt speed can be set to normal or fast with the **PTST - PTSP** command.
- The **PINV** and **TINV** commands invert the direction of pan and tilt and the **SWAP** command sets pan commands to tilt and vice versa. These settings are useful for symmetrical effects with multiple fixtures.

Resetting via DMX

By default, it is possible to reset the whole fixture, reset pan and tilt only or reset effects only by sending a DMX command on the Fixture Control DMX channel (the last of the channels used). This feature can be disabled (to avoid accidental resets in the middle of a show, for example) and enabled in the **DRES** submenu.

If the DMX reset feature is disabled in the **DRES** submenu, it is still possible to override this setting and reset the fixture via DMX by sending DMX value 232 on channel 2 and DMX value zero on channel 1 before applying the reset command on the Fixture Control channel.

Cooling

The **FANS** submenu gives you a choice of three cooling fan settings:

- The default setting **REG** sets fans to temperature-regulated operation. This setting should suit use in all normal situations and ensure excellent service lifetimes for all components.
- The **FULL** setting maximizes cooling and reduces the operating temperature of the components in the head. It is recommended when the MAC 401 Dual™ is used intensively in a warm environment or in fixed installations. Note that this setting will give increased fan noise compared to temperature-regulated fan operation.
- When the **SLNT** setting is selected, Silent mode is activated and head fan speed is reduced to minimum. The base fan will still run. Maximum values allowed for RGB or HSV will be limited (no matter what operating mode is selected), so that less heat is generated. If the LEDs get too hot the fans will revert to Regulated mode. When the LEDs are cool enough the fans shift back to Silent mode. The color wheel channel has lower intensity when Silent mode is engaged.

Whatever cooling mode is selected, a thermal cutout shuts down power to the LEDs if the fixture temperature exceeds safe limits. If this occurs, you must reset the fixture via the control menus or via DMX, or cycle power to the fixture off and on again.

If a thermal shutdown occurs, you are pushing the fixture to its limits. Clean the fixture, particularly the air vents, and check that there is sufficient airflow around the fixture. Consider increasing ventilation, reducing the ambient temperature, or switching to **FULL** mode.

Dimming

DIM allows you to select a dimming curve for overall intensity. You can choose from an optically linear curve, a square-law curve that gives finer control at low intensity and coarser control at high intensity, an inverse square-law curve, and an S-curve that gives finer control at low and high intensities and coarser control at medium intensities (see Figure 6).

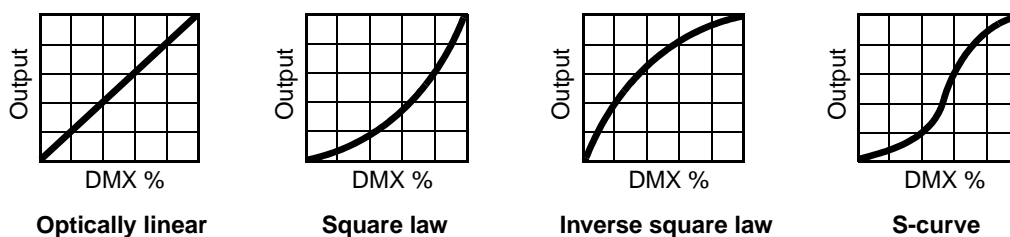

Figure 6: Dimming curve options

Display settings

The **DISP** submenu can be used to adjust the length of time the display is on before it switches off automatically and goes into Sleep mode. You can also deactivate Sleep mode so that the display remains on all the time.

You can set the intensity level of the display using the **DINT** submenu. The default is 100%.

Two modes are available for displaying error messages in the **ERRM** submenu. The default is setting is normal, where error messages appear on the display at 100% intensity (regardless of what the display intensity has been set to), and the service light illuminates. Alternatively, a 'silent' error mode is available, where no error message is displayed, but the service light illuminates.

Effects

This section describes the lighting effects available in the MAC 401 Dual™.

Shutter effect

The electronic 'shutter' effect provides instant open and blackout, variable speed regular and random strobe, and opening/closing pulse effects.

Dimming

Overall intensity can be adjusted using 0 - 100% electronic dimming.

RGB color mixing

Red, green, blue color mixing is available, with 0 - 100% intensity control on one DMX channel for each color.

HSV color mixing

As an alternative to RGB control, hue, saturation and value color control, with one DMX channel for each of these parameters, is available.

CTC

From fixture software v. 1.2.0, the MAC 401 Dual™ can vary the color temperature of any color being displayed. White light color temperature is variable from a very cool blue sky (10 000 K) to a warm sunrise (2000 K). The **PERS** menu contains two settings for the way this works:

- If **PERS - CTC - WITH** (the default setting) is selected, sending a DMX value on the CTC channel will work with RGBW and HSV controls and adjust the temperature of whatever color the fixture or segment is currently displaying.
- If **PERS - CTC - INDP** is selected, sending a DMX value on the CTC channel will act independently from color controls, override any currently selected color and the fixture or segment will switch over to white light with variable color temperature.

Color wheel effect

The electronic 'color wheel' effect gives the convenience and feel of a color wheel in a discharge or incandescent lamp-based fixture. The color wheel effect in the MAC 401 Dual™ lets you fade or snap between 33 different full LEE-referenced colors. You can also scroll continuously forwards or backwards through the colors or display random colors at variable speed.

Pre-programmed dynamic effects 1 and 2

The MAC 401 Dual™ features two superimposable dynamic effects. These effects are pre-programmed macros that give quick access to a variety of effects from the DMX controller without the need for complex programming.

Effects crossfade times for the change from one segment to the next can be set from zero (snap) to approximately one second.

Certain effects divide LEDs into two or four segments for a chase that gives a 'pixel wheel' rotation effect.

Pulse, flip and flicker effects are also available.

The speed of the dynamic effects – including rotation speed and direction of the 'pixel wheel' effect – can be adjusted on a separate DMX channel for each of the two dynamic effects.

Zoom

The motorized zoom varies the beam angle continuously from 20° through to 50°. The zoom can also be set to Hypermode where the beam angle is fixed at 16°.

Pan and tilt

The MAC 401 Dual™ fixture's moving head can be panned through 630° and tilted through 300°. Coarse (8-bit/Most Significant Byte) and fine (16-bit/Least Significant Byte) control of pan and tilt are available in all DMX modes. The fine channels allow fine adjustment of pan and tilt at the position set on the coarse channels.

Bear in mind that if two head modules are installed, the second module will point towards the base, and direct light output will be lost, during a portion of its tilt range.

Service and maintenance



Warning! Read “Safety Information” on page 3 before servicing the MAC 401 Dual™.

Warning! Disconnect the fixture from AC mains power and allow to cool for at least 10 minutes before handling. Do not view the light output from less than 1 meter (3 feet 4 inches) without shade 4-5 welding goggles. Set the zoom to wide angle and work in well-lit conditions. Be prepared for the fixture to light suddenly if connected to power.



Warning! Refer any service operation not described in this user manual to a qualified service technician.



Important! Excessive dust, smoke fluid, and particle buildup degrades performance, causes overheating and will damage the fixture. Damage caused by inadequate cleaning or maintenance is not covered by the product warranty.



The user will need to clean the MAC 401 Dual™ periodically, and it is also possible for the user to remove and install head modules, change the mains fuses and update the firmware. All other service operations on the MAC 401 Dual™ must be carried out by Martin Professional or its approved service agents.

Installation, on-site service and maintenance can be provided worldwide by the Martin Professional Global Service organization and its approved agents, giving owners access to Martin’s expertise and product knowledge in a partnership that will ensure the highest level of performance throughout the product’s lifetime. Please contact your Martin supplier for details.

It is Martin policy to apply the strictest possible calibration procedures and use the best quality materials available to ensure optimum performance and the longest possible component lifetimes. However, LEDs are subject to wear and tear over the life of the product, resulting in gradual changes in color and overall brightness over many thousands of hours of use. The extent of wear and tear depends heavily on operating conditions and environment, so it is impossible to specify precisely whether and to what extent LED performance will be affected. However, you may eventually need to ask Martin Professional to replace LEDs if their characteristics are affected by wear and tear after an extended period of use and if you require fixtures to perform within very precise optical and color parameters.

Cleaning

Cleaning schedules for lighting fixtures vary greatly depending on the operating environment. It is therefore impossible to specify precise cleaning intervals for the MAC 401 Dual™. Environmental factors that may result in a need for frequent cleaning include:

- Use of smoke or fog machines.
- High airflow rates (near air conditioning vents, for example).
- Presence of cigarette smoke.
- Airborne dust (from stage effects, building structures and fittings or the natural environment at outdoor events, for example).

If one or more of these factors is present, inspect fixtures within their first 100 hours of operation to see whether cleaning is necessary. Check again at frequent intervals. This procedure will allow you to assess cleaning requirements in your particular situation. If in doubt, consult your Martin dealer about a suitable maintenance schedule.

Use gentle pressure only when cleaning, and work in a clean, well-lit area. Do not use any product that contains solvents or abrasives, as these can cause surface damage.

You can set the fixture to issue a time alert after a defined number of operating hours has passed to remind you to clean it. This is set by default to 999 hours. You can adjust this threshold from 100-999 hours using the **INFO - AIRF - STTM** menu on the control panel. Whenever the value on the **INFO - AIRF - TOTL** counter exceeds the threshold set on **INFO - AIRF - STTM**, an alert will be displayed on the control panel.

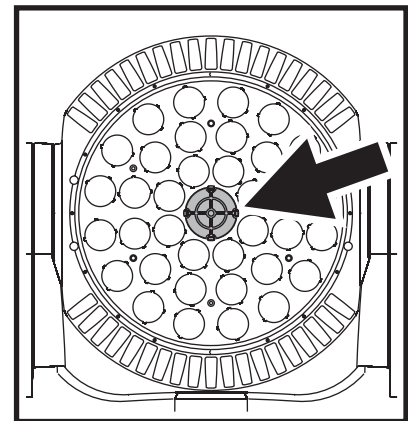
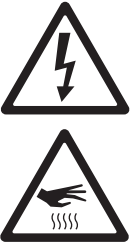

Figure 7: Head air filter



Warning! Disconnect from power and allow to cool before cleaning.

To clean the fixture:

1. Disconnect the fixture from power and allow it to cool for at least 10 minutes.
2. See Figure 7. Unclip and remove the head air filter from the center of the lens plate. Rinse the filter in lukewarm soapy water and blot dry. If the filter is not in perfect condition, replace it with a new one (available from Martin, P/N 62407156).
3. Vacuum or gently blow away dust and loose particles from the outside of the fixture and the air vents at the back and sides of the head and in the base with low-pressure compressed air.
4. Clean the front glass by wiping gently with a soft, clean lint-free cloth moistened with a weak detergent solution. Do not rub the surface hard: lift particles off with a soft repeated press. Dry with a soft, clean, lint-free cloth or low-pressure compressed air. Remove stuck particles with an unscented tissue or cotton swab moistened with glass cleaner or distilled water.
5. Reinstall the head air filter.
6. Check that the fixture is dry before reapplying power.
7. Using the **INFO-AIRF-TOTL** control menu, reset the counter for elapsed time in hours since the fixture was cleaned to **0** by displaying the counter and pressing and holding the up button for five seconds.

Removing and installing head modules

From software version 1.2.0 (available for download free of charge from www.martin.com for fixtures with earlier software versions), two head modules can be installed and controlled in the MAC 401 Dual™.

To remove a head module:

1. Disconnect the fixture from power and allow to cool for at least 10 minutes.
2. See Figure 8. Use a Torx 30 screwdriver to release the four head module retaining screws (arrowed), lift the module away from the yoke slightly, disconnect the head module safety wire and lift the module away from the head.

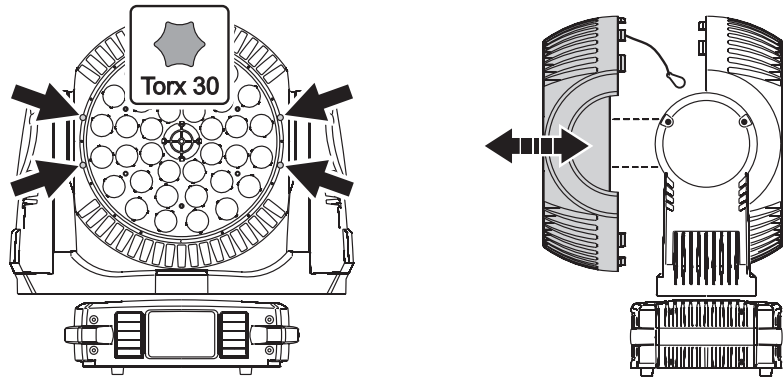

Figure 8: Head module removal/installation

3. Head module installation procedure is the reverse of the removal procedure. See Figure 9. When installing a module, clip the safety wire into the attachment point in the yoke frame, and make sure that the connectors in the module engage in the connectors in the yoke frame while you press the module into position on the head.

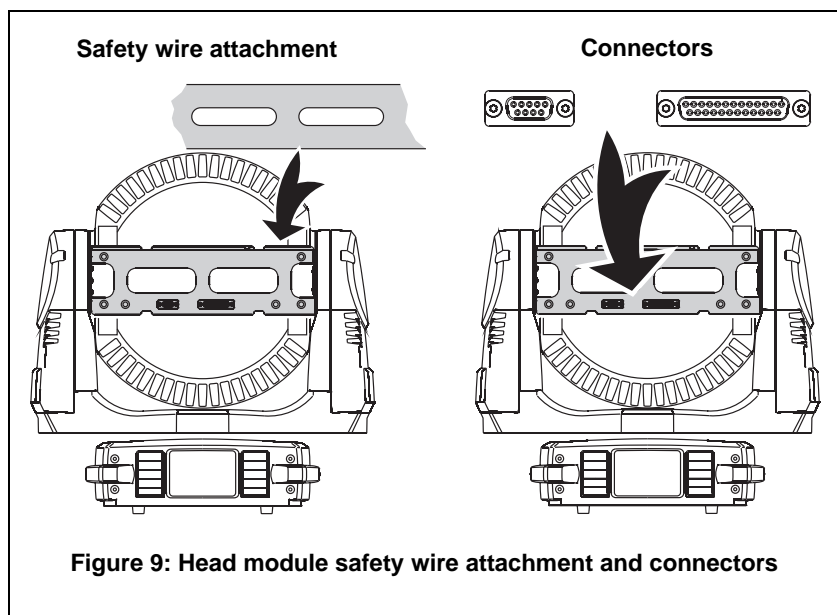

Figure 9: Head module safety wire attachment and connectors

Control menu service utilities

Fixture reset

The **RST** command in the **MAN** menu resets the fixture and can be used as a first remedy if an error occurs.

Software upload

The MAC 401 Dual™ software can be installed and updated by the user. Software updates are available for download on the Product Support pages of the Martin website at www.martin.com

The following are required in order to install software:

- A PC running Windows 98/2000/XP
- The latest version of the MAC 401 Dual™ software, available for download from www.martin.com
- The Martin™ Software Uploader Application, available for download from www.martin.com
- A Martin Universal USB/DMX Interface device (P/N 90702045) with USB and 5-pin male/male XLR cables (supplied with the device).

Use the **UPLD** command in the **SERV** menu to prepare the fixture for a software upload.

Testing

A series of test commands are available in the **TEST** menu, these enable:

- Testing both effects (LED and zoom) and movement at same time
- Testing the LED effects and zoom only
- Testing movement only
- Lighting all segments of the display for five seconds

Fixture readouts

DMX input signal

The **DMXL** menu lets you view the DMX values received on each channel. If the fixture does not behave as expected, reading the DMX values can help you troubleshoot the problem.

Fixture status

The MAC 401 Dual™ gives fixture status readouts in the **INFO** menu:

- Current software/firmware version information is available for the main processor in the base, and for the processors in each of the installed LED modules (one or two).
- The **POHR** counters display hours with power on. The **RSET** counter displays hours since the counter was last reset, and the non-resettable **TOTL** counter displays hours since the fixture was manufactured.
- Temperature readouts from the main PCB in the base as well as the average temperature of driver and pixel (i.e. LED) PCBs in the head are available. In each case, you can view the current temperature, the maximum temperature reached since the readout was last reset, and the maximum temperature reached since manufacture.

Lubrication

In general, the MAC 401 Dual™ does not require lubrication. However, depending on use conditions, the moving parts in the head and zoom mechanisms may eventually require reapplication of lubricant. Excessive noise during pan/tilt and zoom movement is a sign that lubrication may be required. This operation can be carried out by a Martin service partner if necessary.

Fuse replacement



Warning! Disconnect from power before replacing a fuse. Replace fuses with ones of the same type and rating only. Never bypass or bridge a fuse.

The MAC 401 Dual™ is protected by two 10 AT mains fuses located in fuseholders next to the power cable entry (see Figure 1 on page 8).



To replace a fuse:

1. Isolate the fixture from power.
2. Use a flathead screwdriver to open the fuseholders and remove the fuses for testing or replacement.
3. Replace defective fuses with ones of the same type and rating only. Replacement fuses are available from Martin.
4. Reinstall the fuseholders before reapplying power.

If a fuse blows repeatedly, disconnect the fixture from power immediately and consult your Martin supplier.

Diagnostic feedback

If an error occurs, one of the following messages may appear in the MAC 401 Dual™ display:

Message	Condition
CSER	The fixture firmware upload was unsuccessful and has resulted in a Checksum Error
D1CO	Driver PCB 1 temperature cut off
D2CO	Driver PCB 2 temperature cut off
D3CO	Driver PCB 3 temperature cut off
D4CO	Driver PCB 4 temperature cut off
DPER	Display programming error
DREH	Zoom stepper motor driver failure.
DTER	Driver temperature sensor error
F1ER	Fan 1 error
F2ER	Fan 2 error
FBEP	Pan feedback error. The pan correction system could not correct a loss of step.
FBER	Pan/tilt feedback error
FBET	Tilt feedback error. The tilt correction system could not correct a loss of step.
FTCO	Fixture temperature cutoff
MERR	Communication error in EEPROM memory
OPER	Onboard programming error
P1CO	Pixel PCB 1 cut-off
P2CO	Pixel PCB 2 cut-off
P3CO	Pixel PCB 3 cut-off
P4CO	Pixel PCB 4 cut-off
PAER	Pan timeout error. There is a malfunction in the pan position indexing circuit.
PTER	Pixel temperature sensor error
RAME	RAM error
RCER	Real time clock error
RST	Reset. This occurs when power is applied, or when reset is selected in the menu.
RUER	Fixture identification code missing or invalid
SRST	Serial RESET command received via DMX
TIER	Tilt timeout error. There is a malfunction in the tilt position indexing circuit.
YTCO	Yoke temperature sensor cutoff. The temperature has exceeded the allowed maximum and the LEDs have been switched off.
YTER	Yoke temperature circuit error.

DMX protocol

A range of protocols is available for the MAC 401 Dual™. The protocol used depends on how the fixture is configured. For information about configuring for DMX, see “DMX” on page 15.

RGB HSV	RGBX HSX	DMX Value	Percent	Function	Snap/fade	Default value
1	1	0 - 19	0 - 7	Strobe/Virtual shutter effect Shutter closed	Snap	020
		20 - 49	8 - 19	Shutter open		
		50 - 64	20 - 25	Strobe (fast → slow)		
		65 - 69	26 - 27	Shutter open		
		70 - 84	28 - 33	Opening pulse (fast → slow)		
		85 - 89	34 - 35	Shutter open		
		90 - 104	36 - 41	Closing pulse (fast → slow)		
		105 - 109	42 - 43	Shutter open		
		110 - 124	44 - 49	Random strobe (fast → slow)		
		125 - 129	50 - 51	Shutter closed		
		130 - 144	52 - 57	Random opening pulse (fast → slow)		
		145 - 149	58 - 59	Shutter open		
		150 - 164	60 - 65	Random closing pulse (fast → slow)		
		165 - 169	66 - 67	Shutter closed		
		170 - 184	68 - 73	Burst pulse (fast → slow)		
		185 - 189	74 - 75	Shutter open		
		190 - 204	76 - 81	Random burst pulse (fast → slow)		
		205 - 209	82 - 83	Shutter closed		
		210 - 224	84 - 89	Sine wave (fast → slow)		
		225 - 229	90 - 91	Shutter open		
230 - 244	92 - 97	Electronic burst (fast → slow)				
245 - 255	98 - 100	Shutter open				
2	2	0 - 255	0 - 100	Virtual dimmer Closed → open	Fade	0

Table 3: DMX Protocol

RGB HSV	RGBX HSX	DMX Value	Percent	Function	Snap/ fade	Default value
—	3	0 - 19	0 - 7	Dynamic effect 1 No Effect	Snap	0
		20 - 39	7 - 16	Effect 1 - White Single Segment Chase		
		40 - 59	17 - 24	Effect 2 - White Double Segment Chase		
		60 - 79	25 - 32	Effect 3 - Red Single Segment Chase		
		80 - 84	30 - 31	Effect 4 - Green Single Segment Chase		
		85 - 89	32 - 33	Effect 5 - Blue Single Segment Chase		
		90 - 94	34 - 35	Effect 6 - Cyan Single Segment Chase		
		95 - 99	36 - 37	Effect 7 - Magenta Single Segment Chase		
		100 - 104	38 - 39	Effect 8 - Yellow Single Segment Chase		
		105 - 109	40 - 41	Effect 9 - Red Double Segment Chase		
		110 - 114	42 - 43	Effect 10 - Green Double Segment Chase		
		115 - 119	44 - 45	Effect 11 - Blue Double Segment Chase		
		120 - 124	46 - 47	Effect 12 - Cyan Double Segment Chase		
		125 - 129	48 - 49	Effect 13 - Magenta Double Segment Chase		
		130 - 134	50 - 51	Effect 14 - Yellow Double Segment Chase		
		135 - 139	52 - 53	Effect 15 - Yellow Blue Pulse		
		140 - 144	54 - 55	Effect 16 - Green Magenta Pulse		
		145 - 149	56 - 57	Effect 17 - Red Cyan Pulse		
		150 - 154	58 - 59	Effect 18 - Red Green Pulse		
		155 - 159	60 - 61	Effect 19 - Red Blue Pulse		
		160 - 164	62 - 63	Effect 20 - Red Flip 1		
		165 - 169	64 - 65	Effect 21 - Red Flip 2		
		170 - 174	66 - 67	Effect 22 - Green Flip 1		
		175 - 179	68 - 69	Effect 23 - Green Flip 2		
		180 - 184	70 - 71	Effect 24 - Blue Flip 1		
		185 - 189	72 - 73	Effect 25 - Blue Flip 2		
		190 - 194	74 - 75	Effect 26 - White Flip 1		
		195 - 199	76 - 77	Effect 27 - White Flip 2		
		200 - 204	78 - 79	Effect 28 - White Flicker Chase		
		205 - 209	80 - 81	Effect 29 - Rising Pulse		
		210 - 214	82 - 83	Effect 30 - White Flicker		
		215 - 219	84 - 85	Effect 31 - Strobe Pulse		
		220 - 224	86 - 87	Effect 32 - Single segment chase (needs RGB set for color)		
		225 - 229	88 - 89	Effect 33 - Two segment chase (needs RGB set for color)		
		230 - 234	90 - 91	Effect 34 - Double horiz. seg. chase (needs RGB for color)		
		235 - 239	92 - 93	Effect 35 - Double vert. seg. chase (needs RGB for color)		
		240 - 244	94 - 95	Effect 36 - Double opposite chase (needs RGB set for color)		
		245 - 249	96 - 97	Effect 37 - Reserved for future use		
250 - 255	98 - 100	Effect 38 - Reserved for future use				
—	4	0 - 2	0	Dynamic effect 1 speed Stop	Fade	128
		3 - 126	1 - 49	Clockwise rotation, fast → slow		
		127 - 129	50	Stop		
		130 - 253	51 - 99	Counter-clockwise rotation, slow → fast		
		254 - 255	100	Stop		
—	5	0 - 255	0 - 100	Dynamic effect 1 x-fade No fade → max. fade	Fade	0
—	6	0 - 255	0 - 100	Dynamic effect 1 intensity Zero → 100%	Fade	0

Table 3: DMX Protocol

RGB HSV	RGBX HSX	DMX Value	Percent	Function	Snap/ fade	Default value
—	7	0 - 19	0 - 7	Dynamic effect 2 No Effect	Snap	0
		20 - 39	7 - 16	Effect 1 - White Single Segment Chase		
		40 - 59	17 - 24	Effect 2 - White Double Segment Chase		
		60 - 79	25 - 32	Effect 3 - Red Single Segment Chase		
		80 - 84	30 - 31	Effect 4 - Green Single Segment Chase		
		85 - 89	32 - 33	Effect 5 - Blue Single Segment Chase		
		90 - 94	34 - 35	Effect 6 - Cyan Single Segment Chase		
		95 - 99	36 - 37	Effect 7 - Magenta Single Segment Chase		
		100 - 104	38 - 39	Effect 8 - Yellow Single Segment Chase		
		105 - 109	40 - 41	Effect 9 - Red Double Segment Chase		
		110 - 114	42 - 43	Effect 10 - Green Double Segment Chase		
		115 - 119	44 - 45	Effect 11 - Blue Double Segment Chase		
		120 - 124	46 - 47	Effect 12 - Cyan Double Segment Chase		
		125 - 129	48 - 49	Effect 13 - Magenta Double Segment Chase		
		130 - 134	50 - 51	Effect 14 - Yellow Double Segment Chase		
		135 - 139	52 - 53	Effect 15 - Yellow Blue Pulse		
		140 - 144	54 - 55	Effect 16 - Green Magenta Pulse		
		145 - 149	56 - 57	Effect 17 - Red Cyan Pulse		
		150 - 154	58 - 59	Effect 18 - Red Green Pulse		
		155 - 159	60 - 61	Effect 19 - Red Blue Pulse		
		160 - 164	62 - 63	Effect 20 - Red Flip 1		
		165 - 169	64 - 65	Effect 21 - Red Flip 2		
		170 - 174	66 - 67	Effect 22 - Green Flip 1		
		175 - 179	68 - 69	Effect 23 - Green Flip 2		
		180 - 184	70 - 71	Effect 24 - Blue Flip 1		
		185 - 189	72 - 73	Effect 25 - Blue Flip 2		
		190 - 194	74 - 75	Effect 26 - White Flip 1		
		195 - 199	76 - 77	Effect 27 - White Flip 2		
		200 - 204	78 - 79	Effect 28 - White Flicker Chase		
		205 - 209	80 - 81	Effect 29 - Rising Pulse		
		210 - 214	82 - 83	Effect 30 - White Flicker		
		215 - 219	84 - 85	Effect 31 - Strobe Pulse		
		220 - 224	86 - 87	Effect 32 - Single segment chase (needs RGB set for color)		
		225 - 229	88 - 89	Effect 33 - Two segment chase (needs RGB set for color)		
		230 - 234	90 - 91	Effect 34 - Double horiz. seg. chase (needs RGB for color)		
		235 - 239	92 - 93	Effect 35 - Double vert. seg. chase (needs RGB for color)		
		240 - 244	94 - 95	Effect 36 - Double opposite chase (needs RGB set for color)		
		245 - 249	96 - 97	Effect 37 - Reserved for future use		
250 - 255	98 - 100	Effect 38 - Reserved for future use				
—	8	0 - 2	0	Dynamic effect 2 speed Stop	Fade	128
		3 - 126	1 - 49	Clockwise rotation, fast → slow		
		127 - 129	50	Stop		
		130 - 253	51 - 99	Counter-clockwise rotation, slow → fast		
		254 - 255	100	Stop		
—	9	0 - 255	0 - 100	Dynamic effect 2 x-fade No fade → max. fade	Fade	0
—	10	0 - 255	0 - 100	Dynamic effect 2 intensity Zero → 100%	Fade	0
3	11	0 - 200	0 - 77	Zoom Zoom wide → narrow	Fade	0
		201 - 210	78 - 81	Hypermode		
		211 - 255	82 - 100	No function		
4	12	0 - 255	0 - 100	Pan Pan 0 - 630° (128 = centered)	Fade	128
5	13	0 - 255	0 - 100	Pan fine Pan fine (Least Significant Byte)	Fade	0
6	14	0 - 255	0 - 100	Tilt Tilt 0 - 300° (128 = centered)	Fade	128
7	15	0 - 255	0 - 100	Tilt fine Tilt fine (Least Significant Byte)	Fade	0

Table 3: DMX Protocol

RGB HSV	RGBX HSX	DMX Value	Percent	Function	Snap/ fade	Default value
8	16	0 - 9	0 - 1	Fixture control No function	Snap	0
		10 - 14	2 - 3	Reset Entire fixture1		
		15 - 19	4 - 5	No function		
		20 - 24	6 - 7	Reset Effects only1		
		25 - 29	8 - 9	No function		
		30 - 34	10 - 11	Reset Pan & Tilt Only1		
		35 - 39	12 - 13	No function		
		40 - 44	14 - 15	PTSP = NORM (Menu override. Setting unaffected by power on/off)		
		45 - 49	16 - 17	PTSP = FAST (Menu override. Unaffected by power on/off)		
		50 - 54	18 - 19	No function		
		55 - 59	20 - 21	Reserved for Future Use		
		60 - 64	22 - 23	No function		
		65 - 69	24 - 25	Fan Mode - Full (Menu override. Setting unaffected by power on/off)		
		70 - 74	26 - 27	No function		
		75 - 79	28 - 29	Fan Mode - Regulated (Menu override. Setting unaffected by power on/off)		
		80 - 84	30 - 31	No function		
		85 - 89	32 - 33	Fan Mode - Silent (Menu override. Setting unaffected by power on/off)		
		90 - 94	34 - 35	No function		
		95 - 99	36 - 37	Dimmer Curve = LIN (Menu override. Setting unaffected by power on/off)		
		100 - 104	38 - 39	No function		
		105 - 109	40 - 41	Dimmer Curve = SQR (Menu override. Setting unaffected by power on/off)		
		110 - 114	42 - 43	No function		
		115 - 119	44 - 45	Dimmer Curve = ISQR (Menu override. Setting unaffected by power on/off)		
		120 - 124	46 - 47	No function		
		125 - 129	48 - 49	Dimmer Curve = SCUR (Menu override. Setting unaffected by power on/off)		
		130 - 249	50 - 97	No function, reserved for future use		
		250 - 255	98 - 100	Illuminate Display		

Table 3: DMX Protocol

RGB HSV	RGBX HSX	DMX Value	Percent	Function	Snap/ fade	Default value
9	17	0 - 9	0 - 1	Color wheel effect (see also "LEE colors and their RGB equivalents" on page 29) Open (white)	Fade	0
		10 - 14	2 - 3	LEE 790 - Moroccan Pink		
		15 - 19	4 - 5	LEE 157 - Pink		
		20 - 24	6 - 7	LEE 332 - Special Rose Pink		
		25 - 29	8 - 9	LEE 328 - Follies Pink		
		30 - 34	10 - 11	LEE 345 - Fuchsia Pink		
		35 - 39	12 - 13	LEE 194 - Surprise Pink		
		40 - 44	14 - 15	LEE 181 - Congo Blue		
		45 - 49	16 - 17	LEE 071 - Tokyo Blue		
		50 - 54	18 - 19	LEE 120 - Deep Blue		
		55 - 59	20 - 21	LEE 079 - Just Blue		
		60 - 64	22 - 23	LEE 132 - Medium Blue		
		65 - 69	24 - 25	LEE 200 - Double CT Blue		
		70 - 74	26 - 27	LEE 161 - Slate Blue		
		75 - 79	28 - 29	LEE 201 - Full CT Blue		
		80 - 84	30 - 31	LEE 202 - Half CT Blue		
		85 - 89	32 - 33	LEE 117 - Steel Blue		
		90 - 94	34 - 35	LEE 353 - Lighter Blue		
		95 - 99	36 - 37	LEE 118 - Light Blue		
		100 - 104	38 - 39	LEE 116 - Medium Blue Green		
		105 - 109	40 - 41	LEE 124 - Dark Green		
		110 - 114	42 - 43	LEE 139 - Primary Green		
		115 - 119	44 - 45	LEE 089 - Moss Green		
		120 - 124	46 - 47	LEE 122 - Fern Green		
		125 - 129	48 - 49	LEE 738 - JAS Green		
		130 - 134	50 - 51	LEE 088 - Lime Green		
		135 - 139	52 - 53	LEE 100 - Spring Yellow		
		140 - 144	54 - 55	LEE 104 - Deep Amber		
		145 - 149	56 - 57	LEE 179 - Chrome Orange		
		150 - 154	58 - 59	LEE 105 - Orange		
		155 - 159	60 - 61	LEE 021 - Gold Amber		
		160 - 164	62 - 63	LEE 778 - Millennium Gold		
		165 - 169	64 - 65	LEE 135 - Deep Golden Amber		
170 - 174	66 - 67	LEE 164 - Flame Red				
175 - 179	68 - 69	Open (white)				
180 - 201	70 - 78	Color wheel rotation effect Clockwise, fast → slow				
202 - 207	79 - 80	Color wheel stop (freezes at current color)				
208 - 229	81 - 89	Counter-clockwise, slow → fast				
230 - 234	90 - 91	Open (white)				
235 - 239	92 - 93	Random color Fast				
240 - 244	94 - 95	Medium				
245 - 249	96 - 97	Slow				
250 - 255	98 - 100	Open (white)				

The **PGRP** option on the control menu on the fixture defines which LEDs the following 4 channels control. See "Pixel grouping" on page 14. The channels can control:

- All of the LEDs (**PGRP** set to "**ALL**"), or
- Group **A** of 2 vertically split LED groups (**PGRP** set to "**2V**" and four other channels control the opposite segment), or
- Group **A** of 2 horizontally split LED groups (**PGRP** set to "**2H**" and four other channels control the opposite segment), or
- Group **A** of 4 quadrant split LED groups (**PGRP** set to "**1**" and three groups of four other channels control the other three segments).

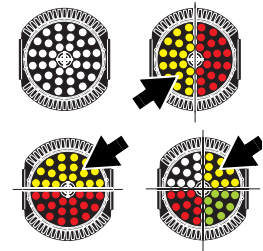

10	18	0 - 255	0 - 100	Red or Hue (depending on operating mode) Color wheel channel must be set to a DMX value from 0 - 9. Zero → 100%	Fade	0
11	19	0 - 255	0 - 100	Green or Saturation (depending on operating mode) Color wheel channel must be set to a DMX value from 0 - 9. Zero → 100%	Fade	0
12	20	0 - 255	0 - 100	Blue or Value (depending on operating mode) Color wheel channel must be set to a DMX value from 0 - 9. Zero → 100%	Fade	0
13	21	0 - 19 20 - 255	0 - 7 8 - 100	CTC (Color Temperature Control) No function CTC 10 000 K → 2 000 K	Fade	0

Table 3: DMX Protocol

RGB HSV	RGBX HSX	DMX Value	Percent	Function	Snap/ fade	Default value
---------	----------	-----------	---------	----------	------------	---------------

The following block of four channels is *only available and used if individual quarter or half groups of LEDs are to be controlled*. The level of control is set using the **PGRP** option on the control menu on the fixture. See "Pixel grouping" on page 14. When available, the channels control:

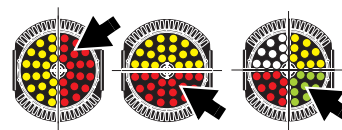

- Group **B** of 2 vertically split LED groups (**PGRP** set to "2V"), or
- Group **B** of 2 horizontally split LED groups (**PGRP** set to "2H"), or
- Group **B** of 4 quadrant split LED groups (**PGRP** set to "1").

14	22	0 - 255	0 - 100	Red or Hue (depending on operating mode) Color wheel channel must be set to a DMX value from 0 - 9. Zero → 100%	Fade	0
15	23	0 - 255	0 - 100	Green or Saturation (depending on operating mode) Color wheel channel must be set to a DMX value from 0 - 9. Zero → 100%	Fade	0
16	24	0 - 255	0 - 100	Blue or Value (depending on operating mode) Color wheel channel must be set to a DMX value from 0 - 9. Zero → 100%	Fade	0
17	25	0 - 19 20 - 255	0 - 7 8 - 100	CTC (Color Temperature Control) No function CTC 10 000 K → 2000 K	Fade	0

The following four channels are *only available and used if individual quarter groups of LEDs are to be controlled (PGRP is set to "1")*. The level of control is set using the **PGRP** option on the control menu on the fixture. See "Pixel grouping" on page 14. The channels control Group **C** of quadrant split LEDs.



18	26	0 - 255	0 - 100	Red or Hue (depending on operating mode) Color wheel channel must be set to a DMX value from 0 - 9. Zero → 100%	Fade	0
19	27	0 - 255	0 - 100	Green or Saturation (depending on operating mode) Color wheel channel must be set to a DMX value from 0 - 9. Zero → 100%	Fade	0
20	28	0 - 255	0 - 100	Blue or Value (depending on operating mode) Color wheel channel must be set to a DMX value from 0 - 9. Zero → 100%	Fade	0
21	29	0 - 19 20 - 255	0 - 7 8 - 100	CTC (Color Temperature Control) No function CTC 10 000 K → 2000 K	Fade	0

The following four channels are *only available and used if individual quarter groups of LEDs are to be controlled (PGRP is set to "1")*. The level of control is set using the **PGRP** option on the control menu on the fixture. See "Pixel grouping" on page 14. The channels control Group **D** of quadrant split LEDs.

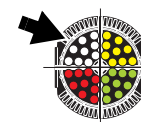

22	30	0 - 255	0 - 100	Red or Hue (depending on operating mode) Color wheel channel must be set to a DMX value from 0 - 9. Zero → 100%	Fade	0
23	31	0 - 255	0 - 100	Green or Saturation (depending on operating mode) Color wheel channel must be set to a DMX value from 0 - 9. Zero → 100%	Fade	0
24	32	0 - 255	0 - 100	Blue or Value (depending on operating mode) Color wheel channel must be set to a DMX value from 0 - 9. Zero → 100%	Fade	0
25	33	0 - 19 20 - 255	0 - 7 8 - 100	CTC (Color Temperature Control) No function CTC 10 000 K → 2000 K	Fade	0

Table 3: DMX Protocol

¹ If DMX Reset is disabled in the onboard control menus, a reset command can only be executed if channel 2 is set to DMX value 232 and channel 1 is set to zero.

The DMX protocol is repeated in full for the second module if fitted to the head. Pan/tilt and fixture control channels have no effect in the second module's DMX protocol.

LEE colors and their RGB equivalents

The table below gives approximate RGB equivalents for the LEE colors available in the color wheel effect (DMX channel 9).

Lee no.	Name	DMX Integer		
		Red	Green	Blue
790	Moroccan Pink	255	62	14
157	Pink	255	33	10
332	Special rose Pink	255	1	12
328	Follies Pink	255	13	25
345	Fuchsia Pink	255	46	63
194	Surprise Pink	255	81	68
181	Congo Blue	92	2	255
71	Tokyo Blue	30	0	255
120	Deep Blue	19	26	255
79	Just Blue	31	93	255
132	Medium Blue	22	161	255
200	Double CT Blue	255	182	200
161	State Blue	255	221	183
201	Full CT Blue	255	135	75
202	Half CT Blue	255	118	45
117	Steel Blue	255	165	59
353	Lighter Blue	214	255	123
118	Light Blue	74	255	186
116	Medium Blue Green	0	255	112
124	Dark Green	69	255	15
139	Primary Green	58	255	0
89	Moss Green	198	255	8
122	Fern Green	251	255	12
738	JAS Green	255	228	0
88	Lime Green	255	138	3
100	Spring Yellow	255	101	0
104	Deep Amber	255	70	0
179	Chrome Orange	255	56	0
105	Orange	255	42	0
21	Gold Amber	255	31	0
778	Millennium Gold	255	25	0
135	Deep Golden Amber	255	17	0
164	Flame Red	255	10	1

Onboard control menus

Single head module operation

When only one module is installed on the head and the **HEAD** menu is set to **SNGL**, the following control menus are available:

Menu	Item	Options	Notes (Default settings in bold print)	
ADDR		1 – XXX	DMX address (default address = 1). The DMX address range is limited so that the fixture will always have enough DMX channels in the 512 available.	
	DMX	PSET	RGBX	RGB mode with dynamic effects
HSX			HSV mode with dynamic effects	
RGB			RGB mode without dynamic effects	
HS			HSV mode without dynamic effects	
PGRP		1	Individual control of 4 pixels (segments)	
		2H	Control of pixels in 2 groups of 2 pixels, horizontal split	
		2V	Control of pixels in 2 groups of 2 pixels, vertical split	
		All	All pixels controlled as one group	
PINV		OFF	Disable pixel inversion	
		ON	Pixel inversion: pixels swapped left to right and top to bottom	
PERS		PTST	PTSP	Pan and tilt speed normal / fast / slow
			SWAP	Swap pan and tilt (pan commands move tilt and vice versa) - off / on
	PINV		Pan inversion (reverse direction pan control) - off / on	
	TINV		Tilt inversion (reverse direction tilt control) - off / on	
	FANS	REG	Cooling fan speed thermostatically regulated	
		FULL	Max. cooling fan speed	
		SLNT	Silent mode. When Silent mode is selected the head fan will turn off. The base fan will still run. Values allowed for RGB or HSV (no matter what operating mode) will be limited to prevent the fixture from producing too much heat. If the LEDs get too hot the fans will revert to Regulated mode. When the LEDs are cool enough the fans shift back to Silent mode. The color wheel channel will have lower intensity in Silent mode.	
	DIM	LIN	Linear dimming curve	
		SQR	Square law dimming curve	
		ISQR	Inverse square law dimming curve	
		SCUR	S-curve dimming curve	
	DRES	OFF	Disable reset via DMX	
		ON	Enable reset via DMX	
	DISP	ON	Display is always on	
		2MN	Display switches off and goes into Sleep mode if the controls have not been pressed for 2 minutes.	
		5MN	Display switches off and goes into Sleep mode if the controls have not been pressed for 5 minutes	
		10MN	Display switches off and goes into Sleep mode if the controls have not been pressed for 10 minutes	
	DINT	0-100	Display intensity. Default= 100	
	ERRM	NORM	Display errors at 100% intensity (regardless of DINT setting) and illuminate the service light.	
		SLNT	Silent error mode. The error message does not appear in the display, but the service lamp is illuminated	
CTC	WITH	Sending a value on a CTC channel adjusts the temperature of whatever color is currently being displayed on segment or fixture		
	INDP	Sending a value on a CTC channel overrides any color being displayed. Fixture or segment switches to white with variable color temperature		
FACT	FACT	LOAD	Return all settings (except calibrations) to factory defaults <i>NB: can take up to 2 minutes to complete!</i>	
	CUS1, CUS2, CUS3	LOAD	Load custom configuration	
		SAVE	Save current custom configuration	

Table 4: Control menu: single head module operation

Menu	Item	Options	Notes (Default settings in bold print)
INFO	VERS	MAIN	CPU firmware version in main processor
		HEAD	CPU firmware version in head processor front module / rear module (if installed)
	pOHR	RSET	Hours of operation since counter reset (to reset counter, display counter and press [Up] for 5 secs.)
		TOTL	Total hours of operation since manufacture
	MTMP	CURR	Display current main PCB temperature
		MSR	Display highest main PCB temperature since last reset
		MR	Display highest main PCB temperature since manufacture
	DTMP	CURR	Display current average driver PCB temperature
		MSR	Display highest driver PCB temperature since last reset
		MR	Display highest driver PCB temperature since manufacture
	PTMP	CURR	Display current average pixel PCB temperature
		MSR	Display highest pixel PCB temperature since last reset
		MR	Display highest pixel PCB temperature since manufacture
	AIRF	TOTL	Current elapsed time in hours since the air filter was cleaned or changed. Display the counter and press the up button for five seconds to reset it. This counter must be reset manually when the air filter is cleaned.
		STTM	Set duration of time alert to be issued after 100- 9999 hours have passed on the TOTL counter, to remind you to clean it, particularly the air filter. The alert appears as long as the value of the TOTL counter is higher than the threshold set here.
SNUM	RDM	Display fixture's RDM ID	
	SNUM	Display fixture's serial number	
MAN	RST		Reset fixture. Press [Enter] to confirm
	ALL	0 – 255	All LEDs, intensity 0 - 100%
	RED	0 – 255	Red LEDs, intensity 0 - 100%
	GRN1	0 – 255	Green 1, intensity 0 - 100%
	GRN2	0 – 255	Green 2, intensity 0 - 100%
	BLUE	0 – 255	Blue, intensity 0 - 100%
	ZOOM	0 – 255	Zoom full wide → zoom full narrow (Hypermode)
	TILT	0 – 255	Full tilt → full opposite tilt
TEST	PAN		0 – 255 Pan full left → pan full right
	TALL		Test LEDs, zoom and pan/tilt movement
	T-FX		Test LEDs and zoom only
	TP-T		Test pan/tilt movement only
DMXL	TDIS		Light all segments in onboard display panel for 5 secs.
	RATE		DMX transmission speed, live, in packets per second
	QUAL		Percent of packets received with errors, live
SERV To access this menu, hold [Enter] pressed for a few seconds	STRT		Decimal value of the DMX start code, live
	PTFB	ON	Enable pan/tilt position feedback/correction system
		OFF	Disable pan/tilt feedback (this setting is not saved when fixture is reset)
	ADJ		Effects adjustment menu (for service use: for full details of this menu, see "Adjustment submenu" on page 35)
	CAL (OF = offset)	P OF	Pan calibration
		T OF	Tilt calibration
	DOF	SURE	Load factory effects calibration settings
	PCBT	SURE	PCB test: for service use only
UPLD	SURE	Manually set fixture to receive software upload	
HEAD	DUAL		Sets head to dual head module operation
	SNGL		Sets head to single head module operation

Table 4: Control menu: single head module operation

Dual head module operation

When you install a second head module on the rear of the head and select **DUAL** in the **HEAD** menu, you have two menus available to you in the control panel: **FRNT** or **REAR**.

- If the **FRNT** menu is selected, all the commands you enter are applied to the fixture and the front head module.
- If the **REAR** menu is selected, all the commands you enter are applied to the fixture and the rear head module. Note that the **PERS**, **FACT**, **DMXL** and **SERV** menus are only available in the **REAR** menu.

FRNT MENU

Menu	Item	Options	Notes (Default settings in bold print)	
ADDR		1 – XXX	DMX address (default address = 1). The DMX address range is limited so that the fixture will always have enough DMX channels in the 512 available.	
	DMX	PSET	RGBX	RGB mode with dynamic effects
HSX			HSV mode with dynamic effects	
RGB			RGB mode without dynamic effects	
HS			HSV mode without dynamic effects	
PGRP		1	Individual control of 4 pixels (segments)	
		2H	Control of pixels in 2 groups of 2 pixels, horizontal split	
		2V	Control of pixels in 2 groups of 2 pixels, vertical split	
		All	All pixels controlled as one group	
PINV		OFF	Disable pixel inversion	
		ON	Pixel inversion: pixels swapped left to right and top to bottom	
INFO		VERS	MAIN	CPU firmware version in main processor
			HEAD	CPU firmware version in head processor front module / rear module (if installed)
	pOHR	RSET	Hours of operation since counter reset (to reset counter, display counter and press [Up] for 5 secs.)	
		TOTL	Total hours of operation since manufacture	
	MTMP	CURR	Display current main PCB temperature	
		MSR	Display highest main PCB temperature since last reset	
		MR	Display highest main PCB temperature since manufacture	
	DTMP	CURR	Display current average driver PCB temperature	
		MSR	Display highest driver PCB temperature since last reset	
		MR	Display highest driver PCB temperature since manufacture	
	PTMP	CURR	Display current average pixel PCB temperature	
		MSR	Display highest pixel PCB temperature since last reset	
		MR	Display highest pixel PCB temperature since manufacture	
	AIRF	TOTL	Current elapsed time in hours since the air filter was cleaned or changed. Display the counter and press the up button for five seconds to reset it. This counter must be reset manually when the air filter is cleaned.	
		STTM	Set duration of time alert to be issued after 100- 9999 hours have passed on the TOTL counter, to remind you to clean it, particularly the air filter. The alert appears as long as the value of the TOTL counter is higher than the threshold set here.	
SNUM	RDM	Display fixture's RDM ID		
	SNUM	Display fixture's serial number		

Table 5: Control menu: dual head module operation, FRNT menu

Menu	Item	Options	Notes (Default settings in bold print)
MAN	RST		Reset fixture. Press [Enter] to confirm
	ALL	0 – 255	All LEDs, intensity 0 - 100%
	RED	0 – 255	Red LEDs, intensity 0 - 100%
	GRN1	0 – 255	Green 1, intensity 0 - 100%
	GRN2	0 – 255	Green 2, intensity 0 - 100%
	BLUE	0 – 255	Blue, intensity 0 - 100%
	ZOOM	0 – 255	Zoom full wide → zoom full narrow (Hypermode)
	TILT	0 – 255	Full tilt → full opposite tilt
TEST	PAN	0 – 255	Pan full left → pan full right
	TALL		Test LEDs, zoom and pan/tilt movement
	T-FX		Test LEDs and zoom only
	TP-T		Test pan/tilt movement only
	TDIS		Light all segments in onboard display panel for 5 secs.

Table 5: Control menu: dual head module operation, FRNT menu

REAR MENU

Menu	Item	Options	Notes (Default settings in bold print)
ADDR	1 – XXX		DMX address of the rear head module (default address = 1). The DMX address range is limited so that the fixture will always have enough DMX channels in the 512 available.
PSET	RGBX		RGB mode with dynamic effects
	HSX		HSV mode with dynamic effects
	RGB		RGB mode without dynamic effects
	HS		HSV mode without dynamic effects
PGRP	1		Individual control of 4 pixels (segments)
	2H		Control of pixels in 2 groups of 2 pixels, horizontal split
	2V		Control of pixels in 2 groups of 2 pixels, vertical split
	All		All pixels controlled as one group
	PINV	OFF ON	
INFO	VERS	MAIN	CPU firmware version in main processor
		HEAD	FRONT = CPU firmware version in head processor front module REAR = CPU firmware version in head processor rear module
	POHR	RSET	Hours of operation since counter reset (to reset counter, display counter and press [Up] for 5 secs.)
		TOTL	Total hours of operation since manufacture
	MTMP	CURR	Display current main PCB temperature
		MSR	Display highest main PCB temperature since last reset
		MR	Display highest main PCB temperature since manufacture
	DTMP	CURR	Display current average driver PCB temperature
MSR		Display highest driver PCB temperature since last reset	
MR		Display highest driver PCB temperature since manufacture	

Table 6: Control menu: dual head module operation, REAR menu

Menu	Item	Options	Notes (Default settings in bold print)
INFO	PTMP	CURR	Display current average pixel PCB temperature
		MSR	Display highest pixel PCB temperature since last reset
		MR	Display highest pixel PCB temperature since manufacture
	AIRF	TOTL	Current elapsed time in hours since the air filter was cleaned or changed. Display the counter and press the up button for five seconds to reset it. This counter must be reset manually when the air filter is cleaned.
		STTM	Set duration of time alert to be issued after 100- 9999 hours have passed on the TOTL counter, to remind you to clean it, particularly the air filter. The alert appears as long as the value of the TOTL counter is higher than the threshold set here.
	SNUM	RDM	Display fixture's RDM ID
SNUM		Display fixture's serial number	
MAN	RST		Reset fixture. Press [Enter] to confirm
	ALL	0 – 255	All LEDs, intensity 0 - 100%
	RED	0 – 255	Red LEDs, intensity 0 - 100%
	GRN1	0 – 255	Green 1, intensity 0 - 100%
	GRN2	0 – 255	Green 2, intensity 0 - 100%
	BLUE	0 – 255	Blue, intensity 0 - 100%
	ZOOM	0 – 255	Zoom full wide → zoom full narrow (Hypermode)
	TILT	0 – 255	Full tilt → full opposite tilt
	PAN	0 – 255	Pan full left → pan full right
TEST	TALL		Test LEDs, zoom and pan/tilt movement
	T-FX		Test LEDs and zoom only
	TP-T		Test pan/tilt movement only
	TDIS		Light all segments in onboard display panel for 5 secs.
PERS	PTST	PTSP	Pan and tilt speed normal / fast / slow
		SWAP	Swap pan and tilt (pan commands move tilt and vice versa) - off / on
		PINV	Pan inversion (reverse direction pan control) - off / on
		TINV	Tilt inversion (reverse direction tilt control) - off / on
	FANS	REG	Cooling fan speed thermostatically regulated
		FULL	Max. cooling fan speed
		SLNT	Silent mode. When Silent mode is selected the head fan will turn off. The base fan will still run. Values allowed for RGB or HSV (no matter what operating mode) will be limited to prevent the fixture from producing too much heat. If the LEDs get too hot the fans will revert to Regulated mode. When the LEDs are cool enough the fans shift back to Silent mode. The color wheel channel will have lower intensity in Silent mode.
	DIM	LIN	Linear dimming curve
		SQR	Square law dimming curve
		ISQR	Inverse square law dimming curve
		SCUR	S-curve dimming curve
	DRES	OFF	Disable reset via DMX
		ON	Enable reset via DMX
	DISP	ON	Display is always on
		2MN	Display switches off and goes into Sleep mode if the controls have not been pressed for 2 minutes.
		5MN	Display switches off and goes into Sleep mode if the controls have not been pressed for 5 minutes
		10MN	Display switches off and goes into Sleep mode if the controls have not been pressed for 10 minutes
	DINT	0-100	Display intensity. Default= 100
	ERRM	NORM	Display errors at 100% intensity (regardless of <i>DINT</i> setting) and illuminate the service light.
		SLNT	Silent error mode. The error message does not appear in the display, but the service lamp is illuminated
CTC	WITH	Sending a value on a CTC channel adjusts the temperature of whatever color is currently being displayed on segment or fixture	
	INDP	Sending a value on a CTC channel overrides any color being displayed. Fixture or segment switches to white with variable color temperature	

Table 6: Control menu: dual head module operation, REAR menu

Menu	Item	Options	Notes (Default settings in bold print)
FACT	FACT	LOAD	Return all settings (except calibrations) to factory defaults <i>NB: can take up to 2 minutes to complete!</i>
	CUS1, CUS2, CUS3	LOAD	Load custom configuration
		SAVE	Save current custom configuration
DMXL	RATE		DMX transmission speed, live, in packets per second
	QUAL		Percent of packets received with errors, live
	STRT		Decimal value of the DMX start code, live
SERV To access this menu, hold [Enter] pressed for a few seconds	PTFB	ON	Enable pan/tilt position feedback/correction system
		OFF	Disable pan/tilt feedback (this setting is not saved when fixture is reset)
	ADJ		Effects adjustment menu (for service use: for full details of this menu, see "Adjustment submenu" below)
	CAL (OF = offset)	P OF	Pan calibration
		T OF	Tilt calibration
	DOF	SURE	Load factory effects calibration settings
	PCBT	SURE	PCB test: for service use only
	UPLD	SURE	Manually set fixture to receive software upload
HEAD	DUAL		Sets head to dual head module operation
	SNGL		Sets head to single head module operation

Table 6: Control menu: dual head module operation, REAR menu

Adjustment submenu

This menu is accessed under **ADJ** in the **SERV** service menu. Adjustments are for service use only.

ADJ	RSET		Reset fixture
	HEAD	RED	Red – 0%/50%/100%
		GRN1	Green 1 – 0%/50%/100%
		GRN2	Green 2 – 0%/50%/100%
		BLUE	Blue – 0%/50%/100%
		ZOOM	Zoom – 0%/50%/100%
	P-T	NEUT	Pan and tilt in neutral (centered) positions
		PNTD	Pan neutral, tilt down
		PNTU	Pan neutral, tilt up
		PLTN	Pan left, tilt neutral
		PRTN	Pan right, tilt neutral
		PLTD	Pan left, tilt down
		PRTU	Pan right, tilt up

Table 7: Adjustment submenu

Troubleshooting

Problem	Probable cause(s)	Remedy
Fixture is completely dead.	No power to fixture.	Check power and connections.
	Fuse blown.	Disconnect fixture from power. Check fuses and replace.
One or more fixtures resets correctly but responds erratically or not at all to the controller.	Fault on data link.	Inspect connections and cables. Correct poor connections. Repair or replace damaged cables.
	Data link not terminated.	Insert termination plug in output connector of the last fixture on the link.
	Incorrect fixture DMX addressing.	Check addressing on fixture and controller. Check fixture is set to correct DMX mode.
	One of the fixtures is defective and is disturbing data transmission on the link.	Unplug XLR in and out connectors and connect them directly together to bypass one fixture at a time until normal operation is regained. Have faulty fixture serviced by Martin service technician.
	XLR pin-out on fixtures does not match (pins 2 and 3 reversed).	Install a phase-reversing cable between the fixtures or swap pins 2 and 3 in the fixture that behaves erratically.
Light output shuts down unexpectedly.	Fixture is too hot.	Clean the fixture, especially air vents. Ensure free airflow around fixture. Check that ambient temperature does not exceed max. permitted level. Switch to FULL cooling mode. If problem persists, contact Martin for advice.

Table 8: Troubleshooting

Specifications

Physical

Length	221 mm (8.7 in.)
Width	505 mm (19.9 in.)
Height	527 mm (20.7 in.)
Weight	21 kg (46.3 lbs.) incl. 2 head modules, excl. brackets

Dynamic Effects

Color mixing	RGB or HSV
Red or hue	0 - 100%
Green or saturation	0 - 100%
Blue or value	0 - 100%
Color temperature control	Variable 10 000 - 2000 K
Electronic 'color wheel' effect	33 LEE-referenced colors plus white, variable speed color wheel rotation effect and random color
Pre-programmed effects	Two superimposable chase/pulse/flip/flicker/strobe/static effects with variable intensity, effect x-fading and 'pixel wheel' rotation speed
Strobe effect	Electronic, with pulse and random effects
Electronic dimming	0 - 100%, four dimming curve options
Zoom	16° (Hypermode), 20° - 50°
Pan	630° with two speed settings
Tilt	300° with two speed settings

Optics

Light source	36 Osram multi-color LED high power emitters
--------------	--

Control and Programming

Control	DMX
Color control modes	RGB, HSV
DMX channels	13/17/21/25/33 depending on control mode & pixel grouping
Setting and addressing	Control panel with LED display
Protocol	USITT DMX512/1990
Transceiver	RS-485

Construction

Color	Black
Housing	High-impact flame-retardant thermoplastic and die-cast aluminum
Protection rating	IP 20

Installation

Mounting points	2 pairs of 1/4-turn locks
Orientation	Any
Minimum distance to illuminated surfaces	200 mm (8 in.)
Minimum distance to combustible materials	200 mm (8 in.)
Minimum distance to persons in the beam zone	1 m (3.4 feet)

Connections

AC power input	Neutrik PowerCon
DMX data in/out	5-pin locking XLR, RJ-45

Electrical

AC power	100-240 V, 50/60 Hz
Maximum total power consumption with one module installed	386 W
Maximum total power consumption with two modules installed	766 W
Power supply unit	Electronic switch mode
Mains fuses	2 x 10 AT

Thermal

Cooling	Filtered forced air, temperature-regulated, low noise
Maximum ambient temperature (Ta max.)	40° C (104° F)
Minimum ambient temperature (Ta min.)	5° C (41° F)
Maximum surface temperature under steady state condition	80° C (176° F)
Total heat dissipation (calculated, +/- 10%), one module installed	1312 BTU/hr
Total heat dissipation (calculated, +/- 10%), two modules installed	2604 BTU/hr

Approvals



EU safety	EN 60598-1, EN 60598-2-17
EU EMC	EN 61000-3-2, EN 61000-3-3, EN 61000-6-2, EN 61000-6-4
US safety	UL 1573
Canadian safety	CAN/CSA-E60598-1:02, CAN/CSA-E598-2-17-98

Included Items

Two Omega clamp attachment brackets with 1/4-turn fasteners	2 x P/N 91602001
User manual	P/N 35000229
Neutrik PowerCon NAC3FCA AC mains power input connector	P/N 05342804
Two 10 AT mains fuses (installed)	2 x P/N 05021029

Accessories

MAC 401 Dual™ double flightcase	P/N 91510150
Color frame kit for MAC 401 Dual™	P/N 91610102
G-clamp	P/N 91602003
Half-coupler clamp	P/N 91602005
Quick trigger clamp	P/N 91602007
Safety wire, universal, SWL (Safe Working Load) 50 kg	P/N 91604003
DMX cable, STP, 1 pair + shield, IEC/UL-CL, 1 m	P/N 91611242
DMX cable, STP, 1 pair + shield, IEC/UL-CL, 2 m	P/N 91611243
DMX cable, STP, 1 pair + shield, IEC/UL-CL, 5 m	P/N 91611244
DMX cable, STP, 1 pair + shield, IEC/UL-CL, 10 m	P/N 91611245
DMX cable, STP, 1 pair + shield, IEC/UL-CL, 20 m	P/N 91611246

Spare parts

10 AT mains fuse	P/N 05021029
Replacement head air filter	P/N 62407156

Related items

Martin Universal USB/DMX Interface Device	P/N 90702045
---	--------------

Ordering Information

MAC 401 Dual™, in cardboard box	P/N 90231200
---------------------------------	--------------

Specifications subject to change without notice. For the latest product specifications, see www.martin.com



Disposing of this product

Martin™ products are supplied in compliance with Directive 2002/96/EC of the European Parliament and of the Council of the European Union on WEEE (Waste Electrical and Electronic Equipment), as amended by Directive 2003/108/EC, where applicable.

Help preserve the environment! Ensure that this product is recycled at the end of its life. Your supplier can give details of local arrangements for the disposal of Martin products.



www.martin.com • Olof Palmes Allé 18 • 8200 Aarhus N • Denmark
Tel: +45 8740 0000 • Fax +45 8740 0010